

IN-WHEEL-MOTOR ELECTRIC VEHICLES AND THEIR ASSOCIATED DRIVETRAINS

Mahmoud Said Jneid¹, Péter Harth², Péter Ficzere³

^{1,2} Budapest University of Technology and Economics, Department of Automotive Technologies, Hungary

³ Budapest University of Technology and Economics, Department of Vehicle Elements and Vehicle-Structure Analysis, Hungary

Received 8 June 2020; accepted 7 July 2020

Abstract: The increasing concerns of reducing CO₂ emissions and eliminating the operational expense of the vehicle have motivated several automotive manufacturers to pave the road for the Electric Vehicle (EV). Nowadays, EVs are becoming more commonplace in the transportation sector. However, EVs and their related technologies are being under development process which forms the magnificent research area for most vehicle manufacturers as well as researchers concerned in this field. Most automotive manufacturers have set a plan as the present trend suggests, the EVs are likely to replace the internal combustion engine (ICE) vehicles shortly. Therefore, the vehicle sector has recently witnessed a critical shift towards the vehicle electrification. Since the beginning of the EV development, the vehicle basic structure has gone through different developing steps as compared to the basic traditional layout. Today, most companies involved in the field of automotive manufacturing, are seeking to develop an EV that takes into account effectiveness, low cost and size as a design criterion. The most remarkable change in vehicle structure during the electrification process was the drivetrain system. Thanks to the recent innovative technologies used in the automotive industry, several companies have succeeded in introducing a unique solution for the most challenging aspects in EV development. Pioneer, automotive manufacturers such as “Protean”, have recently developed the so-called In-Wheel-Motor. In-Wheel-Motor is an innovative compact drivetrain system perfectly fits the EVs requirements. Since the introduction of the IWM, the drivetrain is subjected to a crucial modification as compared to the traditional drivetrain in HEVs and EVs with On-Board-Motor (OBM). In this paper, the most state of the art EVs and their associated drivetrains are reviewed, discussed and compared.

Keywords: electric vehicles, hybrid electric vehicles, vehicle electrification, drivetrain, in-wheel-motor, on-board-motor, central motor, a wheel corner module, x-by-wire, drive-by-wire, accelerate-by-wire, brake-by-wire, steer-by-wire, additive manufacturing.

1. Introduction

The increasing concerns about the environment and the climate changes have led that many researchers in the field of automotive developed the EVs and Hybrid EVs (HEVs) and their related systems for encouraging the use of these vehicles. The

development process of EVs is now at the crossroads, where most of the companies concerned in the field of EVs are currently modifying the structure of the EV and its design in order to reach the goal of obtaining a vehicle with high efficiency and low or even zero-emission. For this purpose, automotive manufacturers are developing new propulsion

³ Corresponding author: ficzere@kge.bme.hu

systems that will crucially reduce the mass and size of the EVs so that emissions can be reduced as well as the total cost.

A simulation methodology for a minimal system cost design of electric powertrains for Battery EVs (BEV) is presented in (Schönknecht *et al.*, 2016). The cost minimization includes all relevant electric powertrain components from the battery, inverter, and electric machine to gearbox. In addition to cost, vehicle dynamics, energy consumption and range are further optimization targets.

Different types of hybrid and pure EV powertrains are evaluated and compared in terms of concept, merits and drawbacks. When adopting series hybrid powertrain, the ICE can be downsized, invest the space packaging, prolong the powertrain life service, improve the vehicle response, and zero-emission is possible. In Pure EVs and (plug-in) hybrid EV the power flow is complicated. Therefore energy management strategy (EMS) must be addressed, so the emission and fuel consumption can be reduced. EMS falls into three types, (i)-rule-based EMSs, (ii)-optimization-based EMSs and (iii)- learning-based EMSs. Each of the three categories has its own advantages and drawbacks (Tran *et al.*, 2020).

To identify the most efficient powertrain architecture for HEVs, different fuel consumption data were analyzed a fuel consumption comparison is performed (Lenzarotto *et al.*, 2018). It is shown that the parallel hybrid powertrain is the most common architecture in markets, but it is not the most efficient solution. However, the series powertrain has limitations due to the

batteries, thanks to some new technologies such as supercapacitors the series powertrain become the best solution in terms of energy efficiency.

Most current conventional (H) EVs have the same structure: On-Board-Motor (OBM), transmission (gearbox), differential, driveshafts and wheels. This layout has been in use for several decades with slight changes in composition. In recent years, EVs and HEVs have gained widespread attention amongst vehicles companies, yet these vehicles still use the same structure.

However, an alternative to developing the architecture of these vehicles is to use the so-called In-wheel-Motor (IWM) or off-board motor rather than the traditional OBM or central motor. IWM is an electric motor installed inside the wheel tire. Using this type of motors, the vehicle can be designed with a higher degree of flexibility and independence, unlike the case for vehicles with central motors. Besides, this design can free more spaces inside the vehicle so that more passengers and cargo spaces can be available, and the battery pack can also be extended (Watts *et al.*, 2010).

From the control perspective, using the IWM wheels control can be implemented individually. Independent control of each wheel allows for a better drive with the possibility of applying modern active safety systems such as ABS. When applying ABS using this type of motors, the torque can be smoothly controlled with high precision within an extensive range as compared to the traditional ABS which only allows discrete torque control based on the sliding conditions.

Most electric motors used to propel EVs are relatively high capacity, and this requires that the inverter and the electronics also have a high capacity (large size), which means occupying more space in the vehicle. For vehicles using IWMs, the drives are independent for each wheel and can be combined with the motor body and installed inside the wheel, thus reducing the power and size of the electronics. In this way, the power cables are intrinsically shortened and the thermal losses significantly reduced, and hence the efficiency is relatively high. IWMs are installed directly on the wheel drive axle and do not need any transmission or gearbox, so another significant primary source of mechanical losses can be eliminated, thus obtaining a higher efficiency as compared to the conventional drive system (Watts *et al.*, 2010).

In-wheel motor technology is optimum solution replacing the ICE with the in-package design that does not invade chassis, passenger or cargo space. Direct-drive IWMs with integrated power electronics provide the equivalent power same as ICEs (Frajnkovic *et al.*, 2018). This design helps reduce vehicle part count and complexity while increasing design freedom and increasing the drivetrain efficiency through reducing losses and weight of the drivetrain (Wang and Wang, 2001), (Vos *et al.*, 2010). Challenges that must be overcome when adopting IWM is the ability to provide adequate power and torque for the desired vehicle size while retaining the same unsprung mass (Watts *et al.*, 2010).

The last generation of IWM can provide high performance and comfortable riding with no degradation due to unsprung mass. The inherited ability of individual

wheel control, improve traction, anti-skid and torque vectoring control compared to other conventional powertrains. Retrofitting HEVs is feasible due to the compact design and packaging technology (Watts *et al.*, 2010). IWM based EVs have obvious more free space, lower center of gravity and reduced total vehicle required parts (Kostic-Perovic, 2012). This means that advantages of range increasing, higher efficiency (Ifedi *et al.*, 2013; Cakir and Sabanovic, 2006) as well as lower cost (Gruber *et al.*, 2011; Pérez, 2011; Heim *et al.*, 2012) are met. In addition, individual better control with lower propulsion response time, torque vectoring, better energy economy, packaging benefits, design flexibility, weight reduction and fuel-saving are main motivators to implement EVs with IWM. Thanks to the advanced technology, IWMs can be produced to have high torque density up to 100 Nm/Kg and up to 1500Nm as peak torque. IP high level protection is also reached, with IP68 IP6k9k the IWM is tested with high jet wash and 1m of water immersed to reflect the high-level sealing. Another competitive is the acoustic noise has been eliminated by complex holistic approach. IWM Key Performance Indicator (KPI) is the small air gap 0.3-2 mm, which is feasible with using advanced machining and drawing tools (Heim *et al.*, 2012; Bicek *et al.*, 2019).

Most IWM EV architectures are reviewed and discussed in terms of geometrical design, cost and production techniques. Housing components are the main cost drivers of IWMs production (Fraser, 2011). Lowering production bill material including industrial production techniques by factor 2-3, leads to the same factor of lowering the powertrain cost (Bicek *et al.*, 2019).

To improve the ride comfort and the vibration resulted from increasing the unsprung mass due to the wheel mass increasing when using the IWM, a hybrid strategy control for suspension is presented. Dynamic vibration absorption structure with additional spring damper system for achieving vibration reduction is developed. Along with controllable damper are used to allocate the hybrid control of the proposed suspension system (Nagaya *et al.*, 2003; Qin *et al.*, 2018).

The steering enhancing is another advantage for EVs equipped with IWM, where individual wheel torque control can be implemented. A dual-steering mode based on vehicle yaw moment and individual wheel torque control of a multi-wheel hub driven vehicle is suggested. The proposed control was verified on an eight-wheel hub motor driven vehicle prototype and also real-time hardware in the loop simulation is carried out. Both results were consistent and indicate that the steering radius was reduced and the vehicle maneuverability is improved (Zhang *et al.*, 2020).

EVs with IWMs have advantage that the vehicle layout can be implemented in a flexible printed vehicle platform. The printed chassis the so-called additive manufacturing technology can significantly reduce the vehicle weight hence improve the fuel economy (Chambon *et al.*, 2017).

The introduction of x-by-wire technology (XBW) in ground transportation will improve the powertrain of both hybrid and pure EVs. With alternative powertrain structure, marking a significant leap towards

efficient and safe EVs (Bolognesi *et al.*, 2003).

2. History of Electric Vehicles

The electric motor came into existence before the ICE, which means that EVs were present before ICE vehicles, but they began to disappear during the oil boom when gasoline was cheap and readily available. The first battery-powered EV was developed in 1834 by Thomas Davenport, and in 1838, Robert Davidson built the first electric locomotive. In the late eighteenth and early nineteenth, EVs began to spread massively on the roads (Leitman and Brant, 2008). During that period, many EVs were designed by individuals and vehicle companies, and the reader can review many of them in (Didik, 2010). However there has been a tremendous improvement over time in the design of electric motors and electronic control devices, unless, EVs serious obstacle is the energy storage system, as long as the walking distance is limited by the battery pack capacity.

EVs could not compete with ICE vehicles due to its limited mileage, however they have employed more in low-speed applications such as EVs used inside cities, battery-powered forklifts, golf vehicles, etc. (Olszewski, 2007). In the last decade, more concentration has been put on researches and developments in the field of EVs, where revision has been made in order to obtain cleaner resource of energy for the powertrain. The challenges that most researchers faced since the redesign and manufacturing of EVs were mostly involved are how to improve the distance range and the speed (Kamiya, 2006).

3. Hybrid Electric Vehicle (HEV) and Their Drivetrain Topologies

Hybrid EVs are those that use different types of energy sources to drive a vehicle. This type of vehicles uses an electric motor that works side by side with an ICE to invest the strengths of each of them during the vehicle life. Energy sources can be connected in several different ways, according to each system. There are many different drivetrain topologies adopted in EVs. Several drivetrains have been investigated in order to obtain the most efficient drivetrain as an attempt to improve the driving range. These systems are approved by automotive manufacturers and are classified according to the type of vehicle into: systems used in hybrid EVs and others used in pure EVs (Kamiya, 2006; Sato *et al.*, 2011).

3.1. Hybrid Series Drivetrain

In this system, the function of the ICE is to drive the generator which in turn charges the battery pack to be ready to supply the electric motor with power or even support the electric motor directly during heavy load driving condition. The electric motor drives the wheels through a reduction device. Figure 1 shows the direction of power flow in this topology (T. M. Corporation, 2003).

3.2. Hybrid Parallel Drivetrain

Here, both the electric motors and ICE provide the power to the drive wheels through the reduction gear so that each of them provides half of the required energy, hence, both can be size down to half. Figure 2 explains the power flow direction in this system (T. M. Corporation, 2003).

3.3. Hybrid Series-parallel (Complex) Drivetrain

The complex drivetrain combines the features of both previous systems; hence this drivetrain is considered the most efficient method because it precisely switches between the operating condition of the ICE and the electric motor which means, obtaining the best and most effective driving performance. Figure 3 demonstrates the direction of power flow in this drivetrain system (T. M. Corporation, 2003).

4. Pure Electric Vehicle and Their Drivetrain Topologies

Hybrid EVs that uses ICE is not the ultimate solution as a clean energy source to operate the vehicle, however, it helped paving the way for EVs that depend entirely on pure electric energy. The 21st century has witnessed a tremendous development in the EVs industry, where the rapid development in the electronics field and the advancement in the technologies of lithium-ion batteries played a significant role in the development of EVs.

Pure EVs are designed to have a sole driving source that is the electric motor. The electric motor is fed with electric energy from a group of battery packs through power inverter driven by a control system that receives driver commands. There are several drivetrain topologies applied in pure EVs, based on the way of mounting of the electric motor. All EVs fall into two main groups: EVs with central or OBM and EVs with IWM.

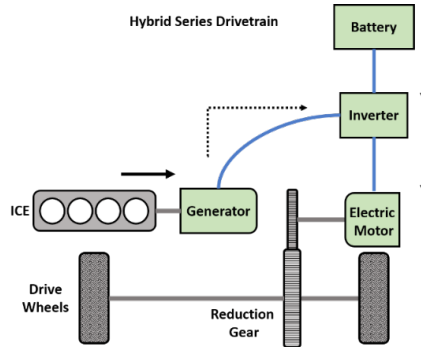

Fig. 1.
Power Flow in Hybrid Serial Drivetrain
Source: (Ifedi, 2014)

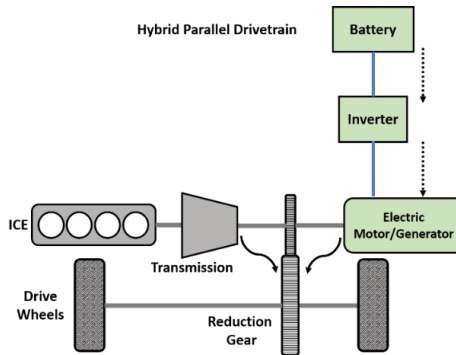

Fig. 2.
Power Flow in Hybrid Parallel Drivetrain
Source: (Ifedi, 2014)

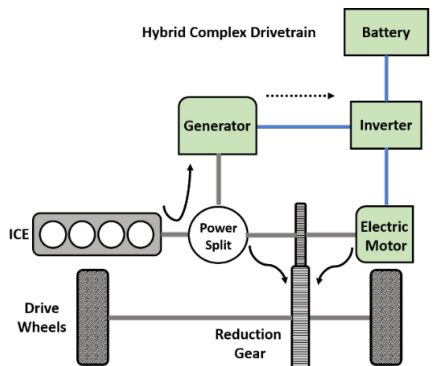

Fig. 3.
Power Flow in Hybrid Complex Drivetrain
Source: (Ifedi, 2014)

4.1. On-Board Motor Drivetrain

4.1.1. Design

The electric motor is installed on the unsprung mass of the vehicle in the centre between the front and rear axles. It provides the driving power for the wheels through the transmission and the differential. It can also be installed on the front drive axle and provides power to the front wheels through the differential; in this case, the vehicle is called a front-wheel drive. The motor can also be installed on the rear-drive axle along with the differential, and the vehicle is a rear-wheel drive. The front and rear wheels drive topologies are explained in Figure 4. All-wheel drive is a possibility by using the central electric motor on the front axle to drive the front wheels and driveshaft to transmit the power to the rear wheels through the differential. Another option for the four wheels drives through installing two central motors on the front and rear axles, as shown in Figure 5. In this case, individual axle drive control is possible.

4.1.2. Features

The onboard motor drivetrain has the following features:

- There are two-wheel driveshafts at each driven axle (i.e. front or rear-drive);
- There is a differential device at each

wheel hub if it contributes to driving the vehicle;

- There is a driveshaft between the front and rear axle if the vehicle is a four-wheel drive with a single motor.

4.1.3. Advantages

When adopting onboard motors, the electric vehicle with its drivetrain has several advantages:

- The simplicity of design due as a single driving axle is used for propulsion or traction (two-wheel drive);
- The four-wheel-drive system is applicable;
- It can be applied in hybrid vehicles as well;
- The possibility of application in traditional vehicles that are intended to be retrofitted into electric.

However, when the drivetrain is to be simple and highly efficient, the onboard motor drivetrain is not the optimal solution due to the following drawbacks.

4.1.4. Disadvantages

- The motor shaft is not installed on the drive axle (but orthogonal);
- It needs a differential at each active drive hub;
- Needs a transmission.

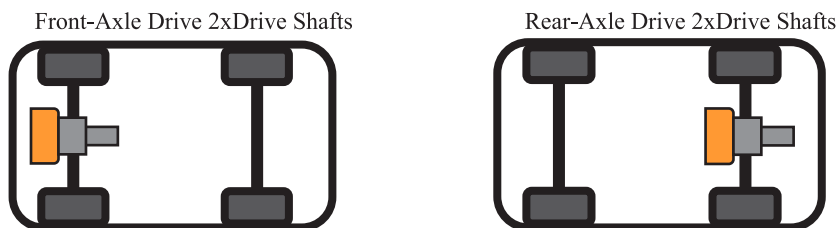

Fig. 4.
Two-Wheel Drivetrain Using Single Central On-Board Motor
Source: (Volkswagen, 2013)

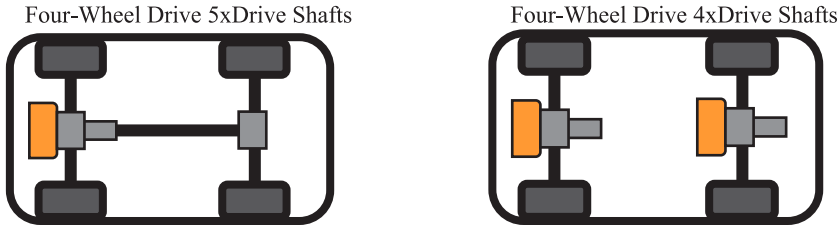

Fig. 5.
All-Wheel Drivetrain Using One -Two Central On-Board Motor
 Source: (Volkswagen, 2013)

4.2. In-wheel Motor Drivetrain

4.2.1. Design

In this type, the electric motor is installed inside the wheel and provides power to it directly, without the need for any transmission. This system is mostly used in electric bicycles, electric scooters, electric driven wheelchairs, and most recently in EVs. The idea of installing the motor inside the wheel rim in an EV is a right choice, in this way it can be ensured that the full output power of the motor is available at the wheel without any mechanical transmission losses. This drivetrain is in high demand and receives a sincere interest by researchers and EV manufacturers today.

The EVs that use this type of motor can be equipped with two motors in the front wheel axle, and thus the vehicle is a front-wheel drive or in the rear wheel axle and the vehicle is a rear-drive as shown in Figure 6. When all-wheel drive is required, the vehicle is equipped with an electric motor at each wheel. Figure 7 shows how the four wheels drivetrain topology using the IWMs.

4.2.2. Features

Pure electric vehicles with IWMs have a simpler design for both chassis and

drivetrain, and they have the following features:

- Does not require any driveshaft;
- Does not require any differential;
- Does not require any transmission.

4.2.3. Advantages

IWM Electric vehicles utilize several advantages in terms of control, efficiency, simplicity and safety as bulleted below:

- The possibility of applying a four-wheel-drive system;
- The motor hubs are connected directly to the wheels;
- High efficiency due to the lack of mechanical losses resulting from drive shafts, transmission and differential;
- The ability to apply active safety systems, regenerative ABS, ESP and TV.

4.2.4. Considerations

Some consideration must be taken into accounts when adopting IWMs as they add extra weight and complexity to the drivetrain. The primary consideration is the followings:

- Increased unsprung mass due to the installation of motors inside the wheels;
- The increase in the mass of the driven elements, and hence the vehicle's overall inertia;

- Requires new vehicle design (can be applied to conventional vehicles after serious modification on vehicle layout);
- The control system is complicated because all IWMs must work in harmony;
- The need for assistance braking system along with electric braking;
- Design difficulty due to the limited space inside the wheel.

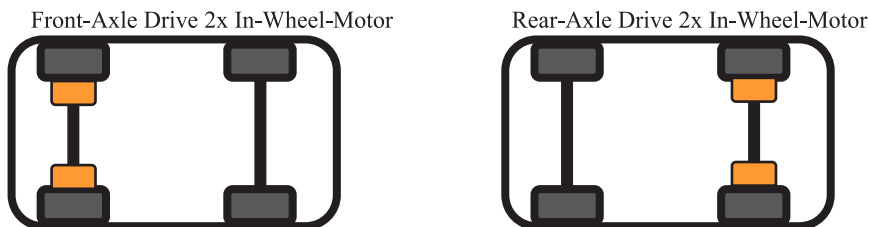

Fig. 6.
 Drivetrain Topologies Using Two In-Wheel Motor
 Source: (Volkswagen, 2013)

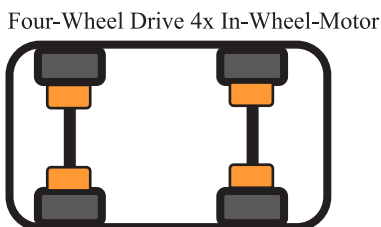

Fig. 7.
 All-Wheel Drivetrain Using Four In-Wheel Motor
 Source: (Volkswagen, 2013)

For traditional ICE vehicle, the drivetrain system consists of conventional mechanical systems; the engine, the transmission system, the exhaust system, the driveshaft and the differential. In a conventional EV, the engine is replaced by an electric motor with inverter and a set of batteries installed at the back, but both the transmission and the driveshaft in addition to the differential remain. In the case of EVs that use IWMs, all the mechanical subsystems of the powertrain are eliminated (engine, transmission, driveshaft differential) and replaced with direct drive IWMs that do not need any driveshaft as they are connected to wheels.

The only remaining system in this type of EVs is the conventional suspension. Many researches on EVs with IWM can be found in references (Isermann *et al.*, 2002; Zhu and Howe, 2007; Ehsani *et al.*, 1997; Hag, 2011; Bretz, 2001; Filippi and Valsan, 2008).

5. Wheel Corner Module (WCM)

Since the Ford T Model was introduced in the early twentieth century, vehicles on the road have gradually evolved in terms of manufacturing technologies. Safety and ride comfort, as well as performance, have gone through several stages of development.

The Wheel Corner Module (WCM) is an innovative way to control the longitudinal, lateral and vertical motion of an EV. WCM also called Active Wheel Module (AWM) or Robot Wheel (RB), designed in a high degree of modularity, where independent operating units can be installed inside the boundaries of the conventional wheel rim and all together form high-level integrated drivetrain unit. WCM represents a vehicle with a controlled manoeuvring system with the purely electronic control technique XBW.

Typical WCM consists of a wheel containing several XBW technologies. Conspicuously speaking; it employs a driving system called (throttle) accelerate-by-wire (ABW), a friction brake system called brake-by-wire (BBW), a manoeuvring steering system called steer-by-wire (SBW) and active suspension system (SS). ABW forms the heart of WCM and comprises an IWM or wheel hub motor (WHM). Generally, braking, steering and suspension systems are controlled utilizing electrical actuators. For the steering system, all functions are controlled by an electrical system that reaches the steering column to the unit system. The steering column may use a conventional steering wheel or another control device such as the control handle (Olszewski, 2007).

This electronic control system employs electromechanical actuators and a set of sensors installed in different places on the body of the vehicle to provide the control unit with real-time information on the position and condition of the vehicle. These sensors include position sensors, speed, acceleration, force, torque, heat, etc. The information received by these sensors could be about vehicle sideslip, vehicle lateral acceleration,

wheels angular velocity steering wheel angle, or even vehicle body speed. All functions of the WCM are controlled electronically by control direct commands to the actuators from one or several electronic control units (Cherno *et al.*, 2006).

6. The Layout of EVs With Corner Module (WCM)

The structure of the traditional EV /HEV consists of several subsystems, which are either electrical or mechanical systems, and some include both. The vehicle structure will be when rearranging the subsystems of a conventional vehicle and replace them with a WCM to form the so-called eCorner Vehicle. WCM EVs or eCorner are those use WCM system at each of the four corners of the vehicle, and for this reason, the EVs use this system are called eCorner vehicles. The only two systems that have not been changed are the overall control system (the ECU) and the body of the vehicle. Otherwise, the change includes the power source or engine and its subsystems as well as subsystems underneath the chassis. Vehicle actuators represent a medium stage between driver commands and the ECU. They can be traditional input devices such as the steering wheel and accelerator/braking pedals, or they are advanced electronic actuators such as steering control knobs or electronic pedals. WCM represents an advanced technology used in EVs as a propulsion system. Nevertheless, some subsystems in this unit are currently used even in some conventional vehicles such as Accelerate-By-Wire (ABW) or BBW. The technologies used in conventional vehicles depend on standard systems, as is the case with most well-known passenger vehicles, where the vehicle motion is mechanically controlled.

EVs that employ WCMs have a higher number of actuators compared to conventional vehicles, which in turn improves vehicle movement control. The number of actuators may be different from one WCM to another, depending on their subsystems. Generally speaking, the greater the number of actuators, the higher the degree of freedom in a vehicle, and thus its motion control is more accurate.

7. X-By-Wire Technology (XBW)

In conventional vehicles, vehicle motion is controlled by a steering wheel and pedals that are mechanically connected to the wheels and the ICE. XBW technology is an innovative technology that controls the longitudinal, lateral and even vertical movement of the vehicle electronically away from traditional mechanical systems. The benefits behind XBW include component minimization, weight reduction and vehicle performance improvement (Bolognesi *et al.*, 2003). This technology has been successfully applied in the field of aviation for decades and has been called in this context Fly-By-Wire (FBW). In the automotive field, there are many nomenclatures for this technology, such as X-By-Wire Electronic System (XBW), Drive-By-Wire (DBW) or Simply-By-Wire (SBW), (Bretz, 2001). The basic principle of XBW technology is to replace all mechanical or hydraulic connections with electrical ones (Bretz, 2001). In turn, the connection between driver and subsystems is no longer. This means that control commands by the driver, interpreted into electric signals through electronic input actuators (e.g. electronic accelerator pedal) and sent to local Electronic Control Unit (ECU) of the specific system (Kamiya, 2006). The ECU in turn, processes and interprets these

commands into control commands and sends them to the output actuators responsible for executing driver desires. Figure 8 shows the structure of the XBW system, as the input devices may include mechanical actuators, sensors and electronic elements in addition to reactive feedback actuators that make the driver feel the same when dealing with conventional devices by applying reaction forces and torques to the input actuator that in direct connection with the driver. Reaction feedbacks are implemented through special electric feedback actuators (e.g. resistive torque of the steering wheel feeling) or mechanical springs and dampers (e.g. reverse force feeling when pressing pedals). When talking about the steering wheel in XBW technology, there is an electric actuator installed on the steering wheel and develop resistive torques feeling similar to the torque generated by the front wheels when the driver tries to move the steering wheel in the conventional steering system. The actual XBW control system consists of a microcomputer, power electronics, electrical actuators, mechanical elements as well as sensors. The control system communicates with output actuators via a system communication bus. The microcomputer is responsible for controlling the actuators, functions, and supervisory monitoring as well as exciting appropriate procedures when some malfunctions occur or even for performance improving purposes (Isermann *et al.*, 2002).

In practice, there are currently three systems of XBW technology applied in electric and traditional vehicles:

- Vehicle longitudinal motion electronic control: controls vehicle speed acceleration and deceleration via vehicle acceleration and braking systems;

- Vehicle lateral motion electronic control: controls the vehicle lateral motion via vehicle steering system;
- Vehicle vertical motion electronic control: In addition to previous

motions control, there is another electronic motion control manage the suspension system. This system is responsible of controlling the vehicle vertical motion.

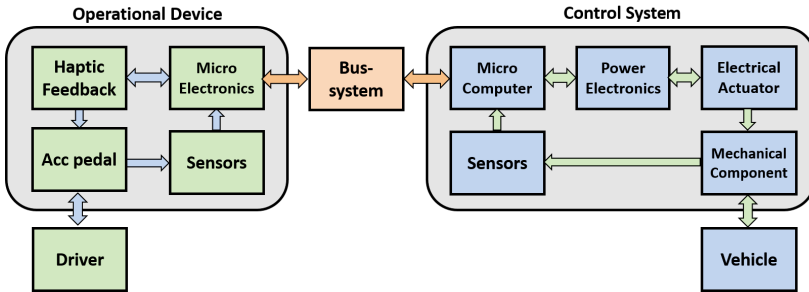

Fig. 8.
The Architecture of The Electronic Control Technology X-By-Wire (XBW)
 Source: (Hag, 2011)

7.1. Vehicle Longitudinal Motion Control by XBW

Longitudinal motion control of the vehicle that uses WCM is done by the electronic vehicle speed system ABW, which is responsible for controlling the IWM speed in order to accelerate the vehicle. This system is also responsible to control the IWM braking torque in regenerative mode and recharge the patter set when the driver applies the brake pedal. In braking mode, the braking torque is restricted by several parameters such as the State of Charge (SOC) of battery set and vehicle speed. Under these conditions, the required braking torque cannot be achieved by the IWM. Therefore, assistance frictional braking system is used to top up the missing part of braking torque. Complementary torque is achieved using separate BBW, which is another electronic braking technology to control the vehicle deceleration.

7.2. Vehicle Vertical Motion Control

WCM often provided with active, semi-active, or even inactive suspension system. Active suspension structure of WCM is shown in Figure 9. Suspension system executes several functions related to absorbing and damping shocks and obstacles imposed on the vehicle while driving:

- Handling vehicle and passengers' weight;
- Improving ride comfort through damping the vehicle vertical acceleration;
- Improving performance and handling via reducing the wheel dynamic weight during cornering;
- Reducing vehicle rotation around its longitudinal and lateral axes.

7.3. Vehicle Lateral Motion Control

Vehicle motion control along its lateral axis is one of the most essential functions

because of its significant role in maintaining the stability of the vehicle and thus ensuring safety for passengers and driver. The system used in traditional vehicles consists of a rack and pinion set which can be considered safe system due of its mechanical rigidity. However, vehicle lateral movement can be controlled by applying electronic steering system called Steer-By-Wire (SBW). SBW comprises the following: electronic control unit, sensors in addition to one or several electric motors. In the case of a conventional steering system, the driver can maintain vehicle instability due to road surface changes (friction coefficient changes) by continuously adjusting the position of the steering wheel.

As for the electronic steering system, the process is different, as the driver commands the desired direction through

an electric actuator (handle), The control unit responsible for the steering system receives the driver intention and based on information from several sensors about the road conditions and the vehicle position, sends control commands to the actuators that modify wheels angle.

The ECU can also control the suspension, vehicle acceleration if necessary and even the braking system are for steering optimization. This process is repeated quickly and continuously within several second frictions until reaching the new position intended by the driver. The crucial difference between the traditional and electronic steering systems is that in the electronic system, the driver controls the vehicle direction directly while, in a conventional system, he controls the front wheels angle.

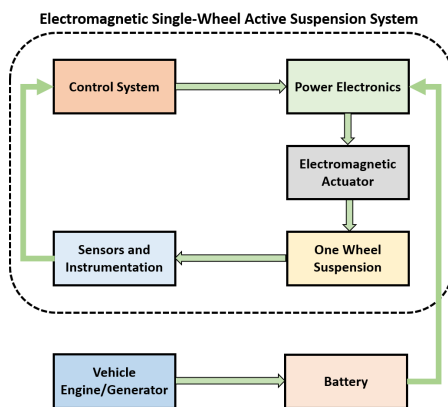

Fig. 9. Architecture of the Electronic Active Suspension System in WCM
 Source: (Martins et al., 2006)

8. Conclusion

CO₂ released by the transportation sector represents a significant ration of total emission resources. Most countries put

reduction of emission CO₂ as their primary goal. In order to achieve this goal, it is necessary for vehicle companies to reduce the rate of emissions outflow from their vehicles. Therefore, EVs and HEVs must be adopted.

Retrofitting existing vehicles to electric ones, seems as difficult task due to the need of serious modification of vehicles structure.

However, the new method of mounting electric motors inside the wheels that is IWM, provides a convenient and easy solution for the electrification mission of traditional vehicle as well as and insures equivalent power to central electric motors. The modular design of WCM also simplifies the production of the new generation of pure EVs. When adopting this type of motors, there is no need to change the design of the regular vehicles in order to electrify the. In addition, more free spaces in the vehicle can be achieved for both luggage and battery pack extension. Electric motors with the direct have their power electronics integrated into the motor body are the best

choice. In this way, the vehicle uses WCM has the following merits:

- Insuring more free space in the vehicle for passengers and extra battery pack;
- Real all-wheel drive application through Independent wheel control;
- Independent wheel slip control optimizes the vehicle stability, response and shortening braking distance;
- Improve the vehicle in terms of performance, safety and comfortability due to elimination of traditional propulsion system components;
- Ease of design and high reliability of the drive system by eliminating transmission, drive shafts and differential;
- Better application of safety systems such as ABS, ESP and other drive systems such as Torque Vectoring TV.

Table 1
Strengths, Weaknesses, Opportunities, Threats (SWOT) of the EVs with IWM technology

Technology	Strengths of Technology	Opportunities of Technology	Weaknesses of Technology	Threats of Technology
In wheel motor	<ul style="list-style-type: none"> o Individual wheel control o New flexible structural design o High level modularity o Minimum vehicle systems o Maximum vehicle free spaces o Light vehicle weight o Direct drive o Minimum cable length o High performance o Fast response o Regenerative braking 	<ul style="list-style-type: none"> o Integrity with different active controls (ABS, ESP and TV) o Fits hybrid and full EVs o Retro-fit ability o 3D printing chassis implementation o Cost reduction o Improve fuel economy o Reduce emissions o Extend battery and range o Increase passenger and cargo space o Elimination of driveshafts and gears o Increase efficiency o Encourage EVs adoption 	<ul style="list-style-type: none"> o Increase unsprung mass o Reduce ride comfort o Limited battery capacity o Restrictive safety requirements o Needs assistance friction braking in emergency braking 	<ul style="list-style-type: none"> o Repeated shock loads o Extreme environment conditions o Harsh road conditions o Extreme temperature due to friction brake o Power cables isolation cracking due bending o Fault in any wheel causes deviation and serious safety concern
Sub-motors Isolated coils Micro inverters	<ul style="list-style-type: none"> o Fault tolerance o Prevent fault spread o Wide operation modes o Individual sub-motor control 	<ul style="list-style-type: none"> o Ensure driver/passengers safety o Improve performance o Improve reliability o Improve efficiency 	<ul style="list-style-type: none"> o Special design o Complex control o Advanced design and electronics technologies 	<ul style="list-style-type: none"> o Fault in more than one sub-motor or micro inverter
Integrated electronics	<ul style="list-style-type: none"> o Free up spaces o Benefit of motor water cooling o Reduce Cables 	<ul style="list-style-type: none"> o Enhance packaging o Increase modularity 	<ul style="list-style-type: none"> o Heat interchange with stator o Difficult maintenance 	<ul style="list-style-type: none"> o Cooling system failure
Toroidal inner stator with min axial length and outer big air-gap	<ul style="list-style-type: none"> o Max torque/power density o Reduce coils length o Reduce copper losses o Free up inner space o Min. weight 	<ul style="list-style-type: none"> o Reduce motor size and cost o Improve efficiency o Improve performance and packaging o Integration with other sub-systems (brake, suspension) 	<ul style="list-style-type: none"> o Stator radius restricted by wheel rim 	

Hollow light outer rotor with high number of permanent magnets	<ul style="list-style-type: none"> Max torque/power density Max. motor diameter High speed/frequency Min iron losses Wheel integration Protect motor of road conditions 	<ul style="list-style-type: none"> Retro-fit ability Fits various standard wheels and rims Improve packaging Enhance resistance to high temperature demagnetization Reduce torque ripple 	<ul style="list-style-type: none"> Requires high inverter switching frequency Special design Increase rotor inertia Slow to reach required speed 	<ul style="list-style-type: none"> Bearing failure Electronics failure Cooling inefficiency
Effective Sealing	<ul style="list-style-type: none"> Protect motor and electronics from outside environment 	<ul style="list-style-type: none"> Handling different extreme road/environment conditions 	<ul style="list-style-type: none"> Needs special material Increase the cost 	<ul style="list-style-type: none"> Sealing failure due to severe road conditions
Outer brake disc with twin brake calipers	<ul style="list-style-type: none"> Free up more inner space Improve motor cooling Reduce rotor bending moments during braking event 	<ul style="list-style-type: none"> Improve packaging Handle more extreme temperature during severe braking via insulate rotor from disc 	<ul style="list-style-type: none"> Special brake disc and calliper design 	<ul style="list-style-type: none"> Increase rotor temperature during heavy braking due to direct contact with brake disc
Active suspension	<ul style="list-style-type: none"> Improve ride comfort Reduce and isolate vibrations 	<ul style="list-style-type: none"> Promising solution for unsprung mass increasing 	<ul style="list-style-type: none"> Special vehicle design Complex and high cost 	<ul style="list-style-type: none"> Loss manoeuvrability Rollover due lateral acceleration
Liquid cooling system	<ul style="list-style-type: none"> Increase performance Increase reliability Handle higher peak power 	<ul style="list-style-type: none"> Motor and electronics design according to continuous power limits Rated power operation for long time Peak power operations for short time Max. captured energy during braking 	<ul style="list-style-type: none"> On-motor body restricted placement 	<ul style="list-style-type: none"> Cooling system defeat
X-by-wire	<ul style="list-style-type: none"> Elimination mechanical and hydraulic components Free up more empty spaces Reduce vehicle overall weight Improve vehicle performance Improve reliability and response Highly precise and accurate electronic motion control Better interpretation for driver commands and faster reaction Improve drivability 	<ul style="list-style-type: none"> Longitudinal, lateral and vertical vehicular motion control Increase fuel efficiency and safety Energy saving Regenerative dry brake Reduces emissions level Push towards self-driving vehicles Fault tolerant by using fault tolerant unit and robust communication system Integration control Low-cost using LSI Technology Redundant CPUs in one chip Self-checking / failsafe technology Optimal clock diversity 	<ul style="list-style-type: none"> Steer-by-wire and brake-by-wire are critical safety systems and must always have a mechanical backup Size and cost constraints 	<ul style="list-style-type: none"> Failure in system especially BBW and SBW Single component failure may lead to whole system failure

References

- Bicek, M.; Peplnjak, T.; Pusavec, F. 2019. Production aspects of direct drive in-wheel-motors, *Procedia CIRP* 81: 1278-1283.
- Bolognesi, P.; Bruno, O.; Landi, A.; Sani, L.; Taponecco, L. 2003. Electric machines and drives for x-by-wire systems in ground vehicles, ResearchGate, In *Proceedings of the 10th European conference on power electronics and applications (EPE)*, 400: 1-16.
- Bretz, E.A. 2001. By-wire cars turn the corner, *IEEE Spectrum* 38(4): 68-73.
- Cakir, K.; Sabanovic, A. 2006. In-wheel motor design for electric vehicles. In *Proceedings of the 9th IEEE International Workshop on Advanced Motion Control*, 613-618.
- Chambon, P.; Curran, S.; Huff, S.; Love, L.; Post, B.; Wagner, R.; Jackson, R.; Green, Jr. J. 2017. Development of a range-extended electric vehicle powertrain for an integrated energy systems research printed utility vehicle, *Applied Energy* 191: 99-110.
- Cherno, A. B.; Szczerba, J. F.; Montousse, J. 2006. Driver control input device for drive-by-wire vehicle. US Patent 6,997,281.

- Didik, F. 2010. History and directory of electric cars from 1834-1987. Available from internet: <http://www.didik.com/ev_hist.htm>.
- Ehsani, M.; Rahman, K.M.; Toliyat, H.A. 1997. Propulsion system design of electric and hybrid vehicles, *IEEE Transactions on industrial electronics* 44(1): 19-27.
- Filippi, S.; Valsan, A. 2008. Strategic analysis of European market for electric corner modules. Frost and Sullivan.
- Frajnkovic, M.; Omerovic, S.; Rozic, U.; Kern, J.; Connes, R.; Rener, K.; Biček, M. 2018. *Structural Integrity of In-Wheel Motors*. SAE Technical Paper (No. 2018-01-1829). 11 p.
- Fraser, A. 2011. In-Wheel Electric Motors. In *Proceedings of the 10th international CTI symposium*, Berlin, Germany, 12-23.
- Gruber, W.; Back, W.; Amrhein, W. 2011. Design and implementation of a wheel hub motor for an electric scooter. In *2011 IEEE Vehicle Power and Propulsion Conference*, 1–6.
- Hag, J. 2011. *Wheel corner modules technology and concept analysis*. Vehicle Dynamics, Aeronautical and Vehicle Engineering, Royal Institute of Technology, Master Thesis. Sweden. 83 p.
- Heim, R.; Hanselka, H.; El Dsoki, C. 2012. Technical potential of in-wheel motors, *ATZ-Automob. Zeitschrift*. 114(10): 4-9.
- Ifedi, C.J. 2014. *A high torque density, direct drive in-wheel motor for electric vehicles*. School of Electrical and Electronic Engineering, Newcastle University. United Kingdom. 224p.
- Ifedi, C.J.; Mecrow, B.C.; Brockway, S.T.; Boast, G.S.; Atkinson, G.J.; Kostic-Perovic, D. 2013. Fault-tolerant in-wheel motor topologies for high-performance electric vehicles, *IEEE Transactions on Industry Applications* 49(3): 1249-1257.
- Isermann, R.; Schwarz, R.; Stolz, S. 2002. Fault tolerant drive-by-wire systems, *IEEE Control Systems Magazine* 22(5): 64-81.
- Kamiya, M. 2006. Development of traction drive motors for the Toyota hybrid system, *IEEE Transactions on Industry Applications* 126(4): 473-479.
- Kostic-Perovic, D. 2012. Making the impossible, possible – overcoming the design challenges of in wheel motors, *World Electric Vehicle Journal* 5(2): 514-519.
- Leitman, S.; Brant, B. 2008. *Build Your Own Electric Vehicle*. McGraw-Hill, Inc. USA. 329 p.
- Lenzarotto, D.; Marchesoni, M.; Passalacqua, M.; Prato, A.P.; Repetto, M. 2018. Overview of different hybrid vehicle architectures, *IFAC PapersOnLine* 51(9): 218–222.
- Martins, I.; Esteves, J.; Marques, G.D.; Da Silva, F.P. 2006. Permanent-magnets linear actuators applicability in automobile active suspensions, *IEEE Transactions on Vehicular Technology* 55(1): 86-94.
- Nagaya, G.; Wakao, Y.; Abe, A. 2003. Development of an in-wheel drive with advanced dynamic-damper mechanism, *JSAE Review* 24 (4): 477–481.
- Olszewski, M. 2007. Report on Toyota Prius motor torque capability, torque property, no-load back EMF, and mechanical losses, Oak Ridge Nat. Lab., US Dept. Energy, Washington, DC.
- Pérez, S.R. 2011. *Analysis of a light permanent magnet in-wheel motor for an electric vehicle with autonomous corner modules*. Master Thesis. Royal Institute of Technology (KTH), Stockholm, Sweden. 103 p.
- Qin, Y.; He, C.; Ding, P.; Dong, M.; Huang, Y. 2018. Suspension hybrid control for in-wheel motor driven electric vehicle with dynamic vibration absorbing structure, *Elsevier, IFAC Papers Online* 51(31) 973–978.

- Sato, Y.; Ishikawa, S.; Okubo, T.; Abe, M.; Tamai, K. 2011. *Development of high response motor and inverter system for the Nissan LEAF electric vehicle*. SAE Technical Paper (No. 2011-01-0350). 8 p.
- Schönknecht, A.; Babik, A.; Rill, V. 2016., *Electric powertrain system design of BEV and HEV applying a multi objective optimization methodology*, *Transportation Research Procedia* 14: 3611-3620.
- T. M. Corporation. 2003. *Toyota Hybrid System THS II*, Japan. 24 p.
- Tran, D.D.; Vafaiepour, M.; El Baghdadi, M.; Barrero, R.; Van Mierlo, J.; Hegazy, O. 2020. *Thorough state-of-the-art analysis of electric and hybrid vehicle powertrains: Topologies and integrated energy management strategies*, *Renewable and Sustainable Energy Reviews* 119: 109596.
- Volkswagen. 2013. *Basics of Electric Vehicles - Design and Function*. SelfStudy Program 820233, Volkswagen Group of America, Inc. 62 p.
- Vos, R.; Besselink, I.J.M.; Nijmeijer, H. 2010. *Influence of in-wheel motors on the ride comfort of electric vehicles*. In *Proceedings of the 10th International Symposium on Advanced Vehicle Control (AVEC10)*, 22-26 August 2010, Loughborough, United Kingdom, 835-840.
- Zhang, Z.; Ma, XJJ; Liu, C.G.; Wei, S.G. 2020. *Dual-steering mode based on direct yaw moment control for multi-wheel hub motor driven vehicles: Theoretical design and experimental assessment*, *Defence Technology* (in print).
- Zhu, Z.Q.; Howe, D. 2007. *Electrical machines and drives for electric, hybrid, and fuel cell vehicles*. In *Proceedings of the IEEE* 95(4): 746-765.
- Wang, R.; Wang, J. 2011. *Fault-tolerant control with active fault diagnosis for four-wheel independently driven electric ground vehicles*, *IEEE Transactions on Vehicular Technology* 60(9): 4276-4287.
- Watts, A.; Vallance, A.; Whitehead, A.; Hilton, C.; Fraser A. 2010. *The technology and economics of in-wheel motors*, *SAE International Journal of Passenger Cars-Electronic and Electrical Systems* 3(2): 37-55.